

REV.	ECN NO	LOCATIONS	DESCRIPTION	DATE	REVISER	APPD

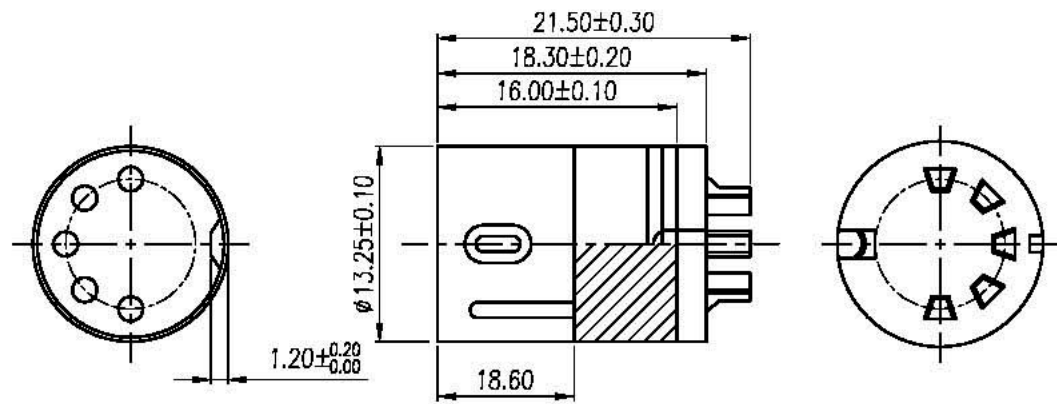

Note:

1. Material:

- 1.1 Insulator: P.B.T UL 94-V0 rated.
- 1.2 Contact: Brass, t=0.20mm.
- 1.3 Shell: Brass, t=0.40mm.

2. Specification:

- 2.1 Current rating: 1 A Max.
- 2.2 Dielectric withstanding voltage: 500 V(ac) for 1 minute.
- 2.3 Contact resistance: 30 mΩ Max.
- 2.4 Insulation resistance: 1000 MΩ Min at DC 500V.
- 2.5 Total unmating force: 7.0 Kgf Max.
- 2.6 Total unmating force: 4.0 Kgf Min.
- 2.7 Temperature range: -55°C~+105°C

3. Finishes:

- 3.1 Contacts: Tin plated.
- 3.2 Shell: Nickel plated or Tin plated.

NO.OF CONTACT	3(180°)	4(210°)	5(180°)	6(240°)	7(270°)	8(270°)
PART NO.	DIN-3P	DIN-4P	DIN-5P	DIN-6P	DIN-7P	DIN-8P
POSITION						

3	Shell	1	Brass	T=0.40mm	Nickel/Tin Plated
2	Contact	5~8	Brass	T=0.20mm	Nickel/Tin Plated
1	Housing	1	P.B.T	UL 94-V0	Black/Green/Purple
No.	Name	Q'ty	Material	Remarks&Thickness	Finish

PART NO:		MATERIAL:		CHANG ENN CO., LTD.	
MODEL NO:		FINSH:			
UNIT: mm	SIZE: A4	COLOR:		PART NAME:	
TOLERANCE UNSPECIFIED		DR: 06/05/05		DIN SOLDER TYPE(M)	
.x ±0.3	.xx ±0.20	CHK: 08/05/05		DWG NO: PND34-01	REV: A0
.xxx ±0.100	ANG. ±1°	APP: 08/05/05		SCALE: 2:1	SHEET: 1 of 1